

INOSITOL PHOSPHATE PHOSPHATASES OF MICROBIOLOGICAL ORIGIN.
INOSITOL PHOSPHATE INTERMEDIATES IN THE DEPHOSPHORYLATION
OF THE HEXAPHOSPHATES OF *MYO*-INOSITOL, *SCYLLO*-INOSITOL, AND
D-CHIRO-INOSITOL BY A BACTERIAL (*PSEUDOMONAS* SP.) PHYTASE*

By D. J. COSGROVE†

[Manuscript received April 20, 1970]

Summary

Inositol phosphate intermediates formed during the enzymic (bacterial phytase) dephosphorylation of the hexaphosphates of *myo*-, *scyllo*-, and *D-chiro*-inositol have been isolated by means of ion-exchange chromatography. Hydrolysis of *myo*-inositol hexaphosphate is believed to proceed via *D-myo*-inositol 1,2,4,5,6-pentaphosphate, *D-myo*-inositol 1,2,5,6-tetraphosphate, *D-myo*-inositol 1,2,5- or 1,2,6-triphosphate or both, *D-myo*-inositol 1,2-diphosphate, and finally *myo*-inositol 2-monophosphate. Hydrolysis of *scyllo*-inositol hexaphosphate is believed to proceed via the 1,2,3,4,5-pentaphosphate, either or both enantiomorphs of DL-1,2,3,4-tetraphosphate, the 1,2,3-triphosphate, and predominantly or solely through one enantiomorph of DL-1,2-diphosphate. The pathway of degradation of *D-chiro*-inositol hexaphosphate is less certain but evidence presented supports a route via the 1,2,3,5,6- and 1,2,3,4,6-pentaphosphates, the 1,2,3,6-tetraphosphate, the 1,2,6-triphosphate, and the 1,6-diphosphate.

I. INTRODUCTION

The use of the techniques of chromatography and electrophoresis has enabled a substantially complete picture of the pathway of dephosphorylation of *myo*-inositol hexaphosphate by wheat bran phytase to be built up (Desjobert and Petek 1956; Tomlinson and Ballou 1962; Cosgrove 1963*a*, 1969*a*; Seiffert and Agranoff 1965; Tate 1968). Confirmation of the structure of the pentaphosphate intermediate as L-*myo*-inositol 1,2,3,4,5-pentaphosphate has been provided by Angyal and Russell (1968) who synthesized the racemate of this isomer. The same pentaphosphate is believed to be produced by a phytase from *Aerobacter aerogenes* (Greaves, Anderson, and Webley 1967), but the pentaphosphate intermediate produced by a soil bacterium (SB2, *Pseudomonas* sp.) (Cosgrove, Irving, and Bromfield 1970) is *D-myo*-inositol 1,2,4,5,6-pentaphosphate (Cosgrove 1969*a*). The latter pentaphosphate has also been isolated from cultures in which *Neurospora crassa* was growing on *myo*-inositol hexaphosphate as a phosphorus source (Johnson and Tate 1969*b*). Greaves, Anderson, and Webley (1967) stated that the enzyme from *A. aerogenes* was inactive against *scyllo*-inositol hexaphosphate but we have found that SB2 phytase has activity against this substrate and can also hydrolyse the other naturally occurring esters, *D-chiro*-inositol hexaphosphate and *neo*-inositol hexaphosphate (Irving and Cosgrove, unpublished data).

* The "D" and "L" usage in this paper is according to the IUPAC/IUB Tentative Cyclitol Nomenclature Rules [*Europ. J. Biochem.* 5, 1 (1968)].

† Division of Plant Industry, CSIRO, P.O. Box 109, Canberra City, A.C.T. 2601.

Soil "phytate" is a mixture of polyphosphates, mainly hexaphosphates, of *myo*-inositol, *scyllo*-inositol, and *D-chiro*-inositol (Cosgrove 1963*b*, 1969*b*) together with a small proportion of *neo*-inositol polyphosphates (Cosgrove and Tate 1963). This paper deals with the application of ion-exchange chromatography to the separation and isolation of intermediates formed by the action of a bacterial phytase (SB2) on *myo*-inositol hexaphosphate, *scyllo*-inositol hexaphosphate, and *D-chiro*-inositol hexaphosphate. Tentative structures are suggested for the isolated components.

II. MATERIALS AND METHODS

(a) Bacterial Phytase Preparation

Cultures of the bacterium (SB2) (Cosgrove, Irving, and Bromfield 1970) were harvested during the logarithmic phase of growth and washed with 0.05M KCl solution. The washed cells were suspended in cold (5°C) 0.05M KCl solution and disintegrated by high pressure extrusion (French and Milner 1955). Cell debris was removed by centrifugation and the cell-free extract used without further purification.

(b) *myo*-Inositol Hexaphosphate

Crystalline sodium phytate (Sigma) was examined by ion-exchange chromatography (Cosgrove 1963*a*) and found to contain no inorganic orthophosphate or phosphate esters other than *myo*-inositol hexaphosphate. It was used as received.

(c) *scyllo*-Inositol Hexaphosphate and *D-chiro*-Inositol Hexaphosphate

These were prepared by phosphorylation of the parent inositols (Cosgrove 1966). The products were isolated as barium salts. Crystalline sodium *scyllo*-inositol hexaphosphate was prepared using a modification of the Johnson and Tate (1969*a*) method for the sodium salt of *myo*-inositol hexaphosphate. *scyllo*-Inositol hexaphosphate (barium salt; 1.0 g) was suspended in water and stirred (4 hr) with excess Dowex AG-50 (H⁺ form). The resin was removed by filtration, the solution adjusted to pH \approx 13.0 with NaOH, and the volume made up to 14 ml. The solution was warmed to 65°C and methanol (5 ml) added. Insoluble material was removed by filtering the hot solution; crystals were deposited spontaneously when the solution was cooled to ambient temperature (20–25°C). The rhombohedral crystals were removed, washed with aqueous methanol (3:1), and air-dried. They were efflorescent and lost 33.1% of their weight on drying at 105°C for 8 hr. Evidently the degree of hydration is similar to that shown by sodium *myo*-inositol hexaphosphate (H₂O, 37.5–40.6%). Attempts to prepare crystalline sodium *D-chiro*-inositol hexaphosphate by this method were unsuccessful.

(d) Ion-exchange Chromatography

(i) *Method A*.—A solution of the mixture, as sodium salts, was applied to a column (10 by 1.2 cm diam.) of Dowex AG-1 (X2; Cl⁻ form; 200–400 mesh) resin. A gradient elution with HCl was then carried out (Cosgrove 1963*a*).

(ii) *Method B*.—A column (62 by 1.0 cm diam.) of Dowex AG-1 (X2; Cl⁻ form; 200–400 mesh) was prewashed with 10 bed volumes of HCl of the concentration to be used in the subsequent separation. The mixture to be fractionated was dissolved in a few millilitres of the same acid solution and applied to the column. More of the same HCl solution was used for elution and 10-ml fractions were collected.

(iii) *Method C*.—Similar to method B. The resin column dimensions were 90 by 1.0 cm diameter.

(iv) *Method D*.—Similar to method A but using Dowex AG-2 resin. The mixing vessel contained 0.1N ammonia solution and the reservoir a solution of sodium chloride (0.5M) in 0.1N ammonia solution.

(e) Cellulose Column Chromatography

Cellulose powder (Cellex MX, Bio-Rad) was suspended in ethanol (1:4 w/v), stirred vigorously for 45 sec, and then used to fill a column (33 by 2 cm diam.). The column was prepared for use by passing through it several bed volumes of a mixture of ethanol (95%) and 1.0M ammonium acetate solution (7:3 v/v). Samples were applied to the column as neutral salts and elution carried out with the ethanol-ammonium acetate mixture. Fractions (25 ml) were collected and suitable aliquots analysed for phosphorus.

(f) Paper Chromatography

(i) *Inositol Phosphates*.—Descending chromatography for 60 hr on Whatman No. 1 paper was used. The paper was prewashed (Cosgrove 1963b) and the solvent mixture was that used by Kerr and Kfoury (1962). Solvent A: n-propanol-14N ammonia-water (5:4:1). Phosphate zones were detected by Harrap's (1960) method.

(ii) *Acyclic Polyols*.—Descending chromatography for 18 hr on Whatman No. 1 paper using the solvent mixture of Grado and Ballou (1961). Solvent B: ethyl acetate-pyridine-water saturated with boric acid (12:5:4). Polyols were detected by the periodate-benzidine method (Smith 1960).

(iii) *myo-Inositol Monophosphates*.—Descending chromatography for 48 hr on Whatman No. 1 paper was used. The paper was prewashed (Cosgrove 1963b) and the solvent mixture was that used by Eisenberg and Bolden (1965). Solvent C: ethanol (95%)–1.0M ammonium acetate (7:3). Phosphate zones were detected by Harrap's (1960) method.

(g) Analytical Methods

(i) *Phosphorus Analysis*.—The methods used have been described elsewhere (Cosgrove 1963a, 1963b).

(ii) *Determination of Phosphorus:Inositol Ratios*.—Inositol determinations on hydrolysates were made using a modification of Launer's method (1962, 1963) as previously described (Cosgrove 1969a).

(h) Hydrolysis of Inositol Hexaphosphates

(i) *Enzymic*.—The barium salt (1.2 g) was converted to a solution of the free acid, as in Section II(c), and the solution adjusted to pH 5.5 (NaOH). Alternatively, a solution of the same concentration was prepared from the crystalline sodium salt. Acetate buffer (pH 5.5; 0.5M; 60 ml) was added to the hexaphosphate solution and the whole made up to 600 ml volume. Sufficient of the bacterial phytase preparation was added to release c. 30% of the combined phosphorus, as inorganic orthophosphate, after incubation (40°C) for 3 hr. The hydrolysate was cooled and stirred (1 hr) with excess Dowex AG-50W (H⁺ form). The resin and precipitated material were removed by filtration and the solution adjusted to pH 7.0 (NaOH). The solution was divided into three equal portions for fractionation by ion-exchange chromatography (method A). Fractions (50 ml) were collected and the various phosphorus-containing components were isolated as barium salts.

(ii) *Enzymic Hydrolysis of myo-Inositol Hexaphosphate to Monophosphate*.—Sodium phytate (Sigma, 5 g) was dissolved in water (400 ml) and the solution adjusted to pH 5.5 (acetic acid). Acetate buffer (pH 5.5; 0.5M; 50 ml) was added and the whole made up to 500 ml volume. Sufficient of the bacterial phytase preparation was added to release c. 70% of the combined phosphorus, as inorganic phosphorus, after incubation (40°C) for 3 hr. The hydrolysate was cooled, stirred with decolorizing charcoal, and filtered. The filtrate was adjusted to pH 8.5 (NaOH) and excess barium acetate solution added. The precipitate was removed by centrifugation, the supernatant was concentrated *in vacuo* at 50°C, and finally poured into ethanol (2 vol.). The precipitated barium salt was collected by centrifugation, washed with ethanol (70%), and finally absolute ethanol before being dried *in vacuo* (0.84 g).

(iii) *Hydrolysis in Acid Solution (pH 4.0)*.—This procedure has been described previously (Cosgrove 1963a).

(i) Identification of Phosphate Intermediates

(i) *Acid-catalysed Phosphate Migration*.—The barium salt (8 mg) was dissolved in 1N HCl (3 ml) in a test tube whose mouth was closed with a glass marble. After being heated in a boiling water-bath for the required period, the tube was cooled and the contents diluted with water (10 ml) before examination by ion-exchange chromatography (method B).

(ii) *Periodate Oxidation*.—The procedure of Johnson and Tate (1969*a*) was used on a sample of ester derived from the corresponding barium salt [80 mg; see Section II(c)] but the oxidation was carried out at pH 4.5 not at pH 2.0. The polyols produced were chromatographed on paper using solvent B.

(iii) *N.M.R. Spectra*.—These were obtained using a Varian HA-100 spectrometer equipped with a frequency synthesizer for irradiating the phosphorus transitions. ^1H -(^{31}P) INDOOR spectra were obtained using the technique of monitoring the height of the low-field proton resonance under partly saturating conditions while frequency-sweeping the phosphorus irradiation source.

III. RESULTS AND DISCUSSION

(a) *myo*-Inositol Hexaphosphate

The mixture of phosphate esters resulting from the partial dephosphorylation of *myo*-inositol hexaphosphate by bacterial phytase (SB2) was fractionated by ion-exchange chromatography (method A). The elution diagram (Cosgrove 1969*a*) resembled that shown in Figure 4 which illustrates the results obtained in a similar experiment with *D*-*chiro*-inositol hexaphosphate. The pentaphosphate and tetraphosphate components from *myo*-inositol hexaphosphate hydrolysates (SB2) have already been reported on (Cosgrove 1969*a*) and the evidence presented, taken in conjunction with the findings of Johnson and Tate (1969*b*) on the intermediates produced by *Neurospora crassa* and the work of Tomlinson and Ballou (1962) on intermediates produced by bran phytase, shows convincingly that they are *D*-*myo*-inositol 1,2,4,5,6-pentaphosphate (I) and *D*-*myo*-inositol 1,2,5,6-tetraphosphate (II) respectively.

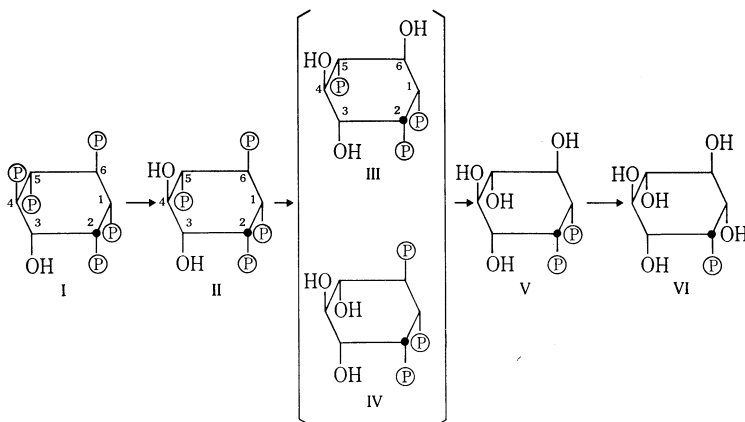

• Positions occupied by axial groups

The lower ester components from a phytase (SB2) hydrolysate of *myo*-inositol hexaphosphate were isolated by ion-exchange chromatography (method A) and

were shown to be tri- and diphosphate by phosphorus:inositol ratio determinations. Their optical rotations are shown in Table 1.

TABLE 1
ROTATIONS OF INOSITOL PHOSPHATES, AS CYCLOHEXYLAMINE
SALTS IN WATER

Compound	Component	c^*	$[\alpha]_D^{22}$
<i>myo</i> -Inositol diphosphate	SB2 hydrolysate	1.35	-1.2°
<i>myo</i> -Inositol triphosphate	SB2 hydrolysate	1.32	-3.2°
<i>scyllo</i> -Inositol diphosphate	2/G (SB2)	1.50	+21.3°
D- <i>chiro</i> -Inositol	Diphosphate	4/E	+18.9°
	Triphosphate	4/D	+15.3°
	Tetraphosphate	4/C	+17.1°
	Pentaphosphate	4/B/1	+42.4°
	Pentaphosphate	4/B/2	+24.8°
	Pentaphosphate	4/B/3	+28.9°
Hexaphosphate	4/A	0.73	+35.2°

* Expressed as weight (g) of the free phosphate ester per 100 ml of solution.

Periodate degradation of the diphosphate component gave material chromatographically indistinguishable from erythritol; no other polyol was detected. The product from SB2 hydrolysis is therefore the 1,2-diphosphate and, as Johnson and Tate (1969b) have shown that the laevorotatory 1,2-diphosphate is the D-isomer, the

TABLE 2
PAPER CHROMATOGRAPHY OF *myo*-INOSITOL DIPHOSPHATES AND
MONOPHOSPHATES

Compound	R_{Pi}^* (solvent A)	R_{Pi}^* (solvent C)
<i>myo</i> -Inositol diphosphate (SB2)	0.80	0.23
<i>myo</i> -Inositol diphosphate (bran)	0.80	0.23
<i>myo</i> -Inositol diphosphate (SB2, isomerized)	{ 0.72 0.80	{ 0.15 0.23
<i>myo</i> -Inositol diphosphate (bran, isomerized)	{ 0.72 0.80	{ 0.15 0.23
<i>myo</i> -Inositol 1-monophosphate		0.56
<i>myo</i> -Inositol 2-monophosphate		0.65
<i>myo</i> -Inositol monophosphate (SB2)		0.65

* Movement relative to that of inorganic orthophosphate.

SB2 product must be D-*myo*-inositol 1,2-diphosphate (V). Comparison of this diphosphate with the corresponding component from a bran phytase hydrolysate showed that the two behaved identically on paper chromatograms. Heating either diphosphate with acid (1N HCl; 100°C for 20 min) resulted in a mixture of two components (Table 2). Periodate degradation of the triphosphate component did

not produce any recognizable polyol components other than a small quantity of erythritol. From consideration of the structures of the tetraphosphate (II) and diphosphate (V) it would appear that the triphosphate must be either the 1,2,5- (III) or 1,2,6-triphosphate (IV), or a mixture of the two. The former may be resistant to periodate, as the 1,3,6-triphosphate is known to be (Tomlinson and Ballou 1962); if degradable by periodate it should give sorbitol. The 1,2,6-triphosphate (IV) is known to be oxidized by periodate giving finally arabitol (Tomlinson and Ballou 1962; Johnson and Tate 1969*b*) although the latter authors obtained only small yields of this polyol. This suggests that correct conditions for the reaction series have not yet been established. The nature of the triphosphate intermediate in the hydrolysis of *myo*-inositol hexaphosphate by SB2 phytase remains uncertain.

The crude monophosphate salt was shown to contain inorganic orthophosphate and attempts were made to purify it by ion-exchange chromatography using the

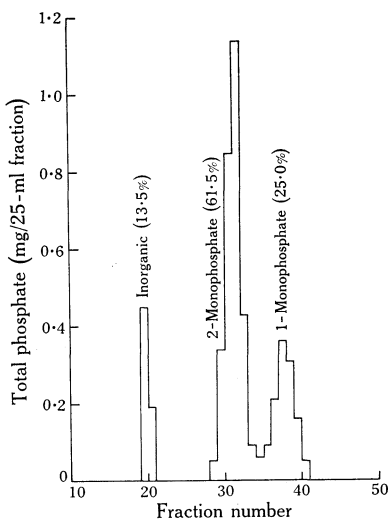

Fig. 1.—Elution pattern from a cellulose column of a commercial sample of *myo*-inositol 2-monophosphate (30 mg of the dicyclohexylamine salt).

method of Kerr and Kfoury (1962). The separation of inorganic orthophosphate from inositol monophosphate was poor but great improvement was effected by buffering the sodium chloride solution used in gradient elution to $\text{pH} \approx 11.0$ (method D). Further investigation of the system revealed that satisfactory separation of inorganic orthophosphate from inositol monophosphate cannot be effected unless the chloride gradient is buffered to at least $\text{pH} 8.0$ and preferably above this. Presumably, at higher pH values the inorganic orthophosphate is present largely as PO_4^{3-} and is therefore more difficult to elute from an anion-exchange resin than *myo*-inositol monophosphate which cannot carry more than a double negative charge. At $\text{pH} \approx 11.0$ (method D) inositol monophosphate is eluted in fractions 11–13 and inorganic orthophosphate in fractions 20–22.

The paper chromatography of *myo*-inositol monophosphates was investigated thoroughly by Pizer and Ballou (1959) who concluded that the various isomers could be separated satisfactorily by only one solvent system, namely, isopropanol–

ammonia-water (70:10:20 v/v). Although this system has the disadvantages of being effective only at temperatures above 30°C and being impracticable for column chromatography, it has been used extensively by later workers. I have found that the solvent used by Eisenberg and Bolden (1965) satisfactorily separates mixtures of 1-monophosphate and 2-monophosphate either on paper or on cellulose columns.

Figure 1 illustrates the elution of a commercial sample of *myo*-inositol 2-monophosphate (Sigma) from a cellulose column. Mild acid isomerization of the main component (Pizer and Ballou 1959) and rechromatography of the product confirmed that the main contaminant was 1-monophosphate.

A sample of *myo*-inositol monophosphate from an SB2 hydrolysate was purified by ion-exchange chromatography (method D) and then examined by cellulose column chromatography. No trace of 1-monophosphate was detected, all the eluted phosphorus being in one component, 2-monophosphate (VI). After mild acid isomerization of a sample of monophosphate (SB2), cellulose column chromatography of the products gave results similar to those shown in Figure 1, the expected mixture of 1-monophosphate and 2-monophosphate.

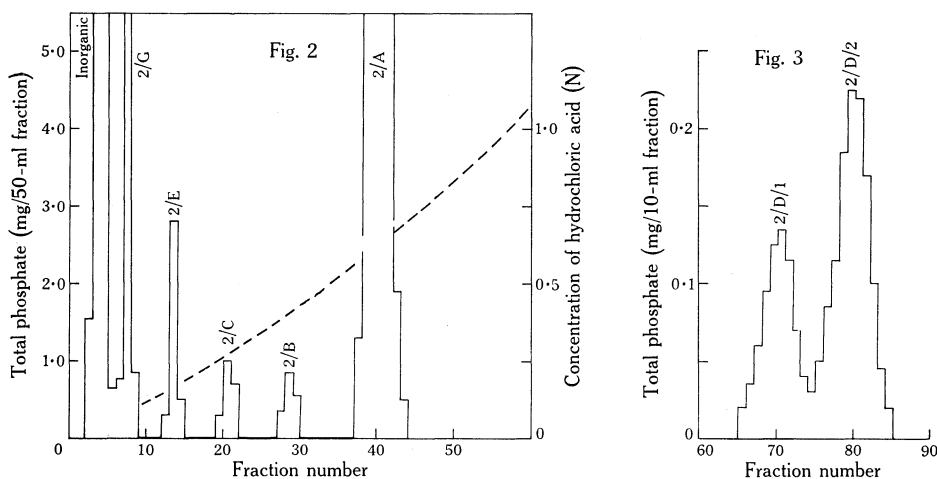

Fig. 2.—Elution pattern from a Dowex-1 (Cl^- form) column of *scyllo*-inositol hexaphosphate (from 0.4 g of the barium salt), after partial hydrolysis with bacterial phytase (SB2). The broken line indicates the HCl gradient.

Fig. 3.—Elution pattern (0.26N HCl) from a Dowex-1 (Cl^- form) column of a *scyllo*-inositol tetraphosphate component (2/D) (8 mg of the barium salt).

The absence of *myo*-inositol 1-monophosphate from SB2 hydrolysates is in contrast to its reported presence in bran phytase hydrolysates (Tomlinson and Ballou 1962). It must be pointed out, however, that no information on the purity of the *myo*-inositol hexaphosphate used by Tomlinson and Ballou (1962) is available; if *myo*-inositol 1,3,4,5,6-pentaphosphate was present as a contaminant it could well have been the precursor of the 1-monophosphate.

(b) *scyllo*-Inositol Hexaphosphate

The mixture of phosphate esters resulting from the partial dephosphorylation of *scyllo*-inositol hexaphosphate by bacterial phytase (SB2) was fractionated by

ion-exchange chromatography (method A). The elution diagram is shown in Figure 2. It differs from the pattern exhibited by enzymic hydrolysates of *myo*-inositol hexaphosphate (Cosgrove 1963a) which usually resembles Figure 4. In the latter case the intermediates are each formed and hydrolysed at approximately the same rate (Desjobert and Petek 1956; Tomlinson and Ballou 1962); therefore, at the stage of hydrolysis illustrated in Figure 4, i.e. where a large proportion of the hexaphosphate remains unhydrolysed, the amounts of intermediates present are in the order, pentaphosphate > tetraphosphate > triphosphate > diphosphate. The results shown in Figure 2, however, can be interpreted as showing that *scyllo*-inositol hexaphosphate and the diphosphate are much more resistant to hydrolysis than the penta-, tetra-, and triphosphate esters. In fact, the tetra- and triphosphates can more readily be obtained by enzymic hydrolysis of *scyllo*-inositol pentaphosphate; the latter is easily isolated from acid hydrolysates of *scyllo*-inositol hexaphosphate or from the products of phosphorylation of *scyllo*-inositol (Cosgrove 1966).

TABLE 3
PAPER CHROMATOGRAPHY OF *scyllo*-INOSITOL DIPHOSPHATES
AND TRIPHOSPHATES

Compound	Component	R_{P_1} *
<i>scyllo</i> -Inositol diphosphate	2/G (SB2)	0.82
<i>scyllo</i> -Inositol diphosphate	2/G (acid)	0.73, 0.82
<i>scyllo</i> -Inositol triphosphate	2/E (SB2)	0.59
	2/E (acid)	0.59
<i>scyllo</i> -Inositol triphosphate	2/F (acid)	0.52

* Movement relative to that of inorg. orthophosphate.

Component 2/A is residual hexaphosphate; phosphorus:inositol ratio determinations showed that 2/B, 2/C, 2/E, and 2/G were pentaphosphate, tetraphosphate, triphosphate, and diphosphate respectively. When a mixture formed by partial hydrolysis of *scyllo*-inositol hexaphosphate (110°C for 180 min, pH 4.0) was fractionated (method A), all the above components were found to be present but, in addition, 2/D (fractions 18 and 19) and 2/F (fractions 11 and 12) were detected. 2/D can be further resolved into two components 2/D/1 and 2/D/2 (method C; elution with 0.26N HCl) (Fig. 3); heating 2/D in 1N HCl (100°C for 80 min) transforms it into a mixture of 2/D and 2/C which can easily be resolved by ion-exchange chromatography (method A). The three theoretically possible tetraphosphates of *scyllo*-inositol are thus accounted for, viz. 2/C, 2/D/1, and 2/D/2.

Rechromatography of component 2/E (acid) (method B; elution with 0.2N HCl) did not further resolve it, and attempts to resolve 2/F (method B; elution with 0.15N HCl) were also unsuccessful. Heating 2/E in 1N HCl (100°C for 80 min) transformed it into a mixture of 2/E and 2/F. Neither 2/E (acid) nor 2/F showed more than one phosphorus-containing component when examined by paper chromatography

(solvent A) (Table 3). A further attempt to resolve either 2/E (acid) or 2/F was made by chromatography on Dowex AG-1 (X2; formate form; 200–400 mesh) using Bartlett's (1959) method, i.e. gradient elution with sodium formate solution (0–4M; pH 2.9). This method failed even to satisfactorily resolve a mixture of 2/E and 2/F and was not investigated further. Theoretically, *scyllo*-inositol can give rise to three triphosphates; if these are all present in the acid hydrolysate then either 2/E (acid) or 2/F must be a mixture of two substances.

Component 2/G appeared in both enzymic and acid hydrolysates, but when examined by paper chromatography (solvent A) the product from the latter, 2/G (acid), showed two phosphorus-containing zones, whereas the enzymic product, 2/G (SB2), showed only one (Table 3). Component 2/G (SB2) was the only optically active intermediate detected in the SB2 hydrolysis products (Table 1).

Periodate degradation of 2/E (SB2) gave material chromatographically indistinguishable from xylitol; no other polyol was detected (solvent B). Similar treatment of 2/G (SB2) gave material chromatographically indistinguishable from threitol; again, no other polyol was detected (solvent B).

TABLE 4
¹H N.M.R. SPECTRA

Compound	Component	δ HCOP (p.p.m.)*	δ HCOD (p.p.m.)*	Relative Areas of Peaks
<i>scyllo</i> -Inositol pentaphosphate	2/B	–3.01	–2.67	5:1
<i>scyllo</i> -Inositol tetraphosphate	2/D/1	–2.87	–2.70	4:2
<i>scyllo</i> -Inositol tetraphosphate	2/D/2	–2.95	–2.69	4:2
<i>scyllo</i> -Inositol tetraphosphate	2/C (SB2)	–2.89	–2.54	4:2

* Chemical shifts in parts per million measured on D₂O solutions of sodium salts relative to *t*-butanol as internal reference standard.

Proton n.m.r. spectra (Table 4) do not allow structural assignments to be made for the three tetraphosphates although they are sufficiently different for identification purposes once the structures are known. Strong evidence that component 2/C is, in fact, DL-1,2,3,4-tetraphosphate (VII) was provided by its INDOE spectrum; this was symmetrical and had two peaks. The INDOE spectrum of component 2/D/1 had a single peak, consistent with that expected for the 1,2,4,5-tetraphosphate (VIII); the spectrum of 2/D/2 was asymmetrical with three peaks, consistent with that expected for the 1,2,3,5-tetraphosphate (IX).

Component 2/E (SB2) must contain the 1,2,3-triphosphate (X) as it gives rise to xylitol by periodate degradation. As DL-1,2,3,4-tetraphosphate is theoretically capable of dephosphorylation to DL-1,2,4-triphosphate (XI) also, the possibility arises that 2/E (SB2) is a mixture of (X) and (XI). If the latter is degraded by periodate it should produce iditol and this polyol was not detected in the products

from 2/E (SB2). It is known, however, that some inositol triphosphates possessing free vicinal hydroxyl groups are resistant to attack by periodate (Tomlinson and Ballou 1962); it is not known whether DL-*scyllo*-inositol 1,2,4-triphosphate falls into this category.

As 2/G (SB2) is optically active and gives only threitol on periodate degradation it must contain at least one enantiomorph of DL-*scyllo*-inositol 1,2-diphosphate (XII). Paper chromatographic evidence (Table 3) shows that it cannot be a mixture of all three possible diphosphates; the absence of xylitol in the periodate degradation products precludes the presence of (XIV); therefore, it is either the 1,2-diphosphate alone or a mixture of this and the 1,4-diphosphate (XIII). The latter, if present, would be degraded by periodate to formic acid and carbon dioxide (Tomlinson and Ballou 1961).

The following scheme illustrates the proposed pathway of dephosphorylation of *scyllo*-inositol hexaphosphate, structures enclosed in square brackets representing intermediates in possible alternative routes through the triphosphate and diphosphate stages:

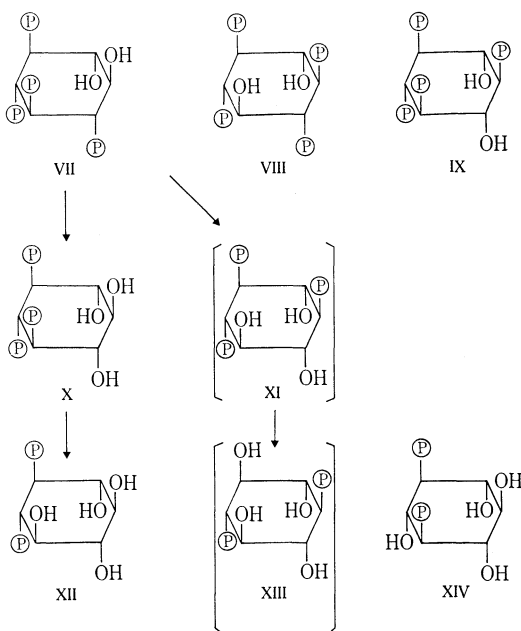

(c) D-chiro-Inositol Hexaphosphate

The mixture of phosphate esters resulting from the partial dephosphorylation of D-chiro-inositol hexaphosphate by bacterial phytase (SB2) was fractionated by ion-exchange chromatography (method A). The isolated components, 4/B, 4/C, 4/D, and 4/E (Fig. 4) were identified as penta-, tetra-, tri-, and diphosphate respectively by means of phosphorus:inositol ratio determinations. 4/A was residual hexaphosphate.

Rechromatography of component 4/B (method B) resolved it into two components, 4/B/1 and 4/B/2, as shown in Figure 5. Heating 4/B/2 in 1N HCl (100°C for 20 min) transformed it into a mixture of 4/B/2 and yet another pentaphosphate, 4/B/3 (Fig. 5). These three substances, 4/B/1, 4/B/2, and 4/B/3 account for all possible pentaphosphates of *D-chiro*-inositol. Acid-catalysed isomerization of 4/B/1 did not take place unless more extreme conditions were used (100°C for 80 min). Attempts to further resolve component 4/C by ion-exchange chromatography (method B) were unsuccessful as were similar efforts to resolve 4/D.

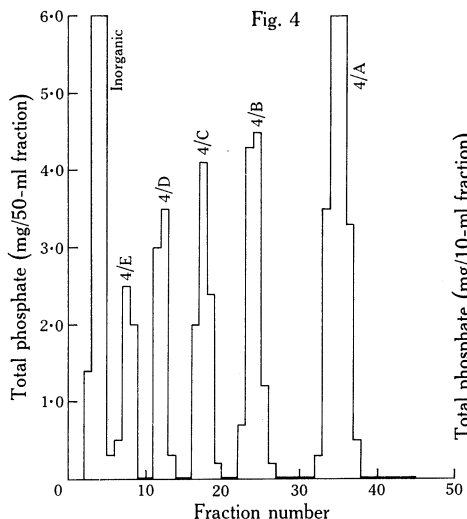

Fig. 4

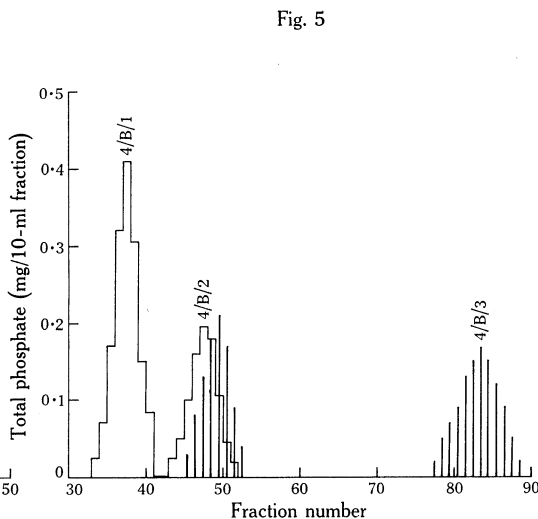

Fig. 5

Fig. 4.—Elution pattern from a Dowex-1 (Cl^- form) column of *D-chiro*-inositol hexaphosphate (from 0.4 g of the barium salt), after partial hydrolysis with bacterial phytase (SB2).

Fig. 5.—Elution patterns (0.48N HCl) from a Dowex-1 (Cl^- form) column of a *D-chiro*-inositol pentaphosphate fraction (4/B; 8 mg of the barium salt; open columns) and an acid-isomerized (1N HCl, 100°C for 20 min) *D-chiro*-inositol pentaphosphate (4/B/2; 8 mg of the barium salt; solid columns).

Periodate degradation of 4/D gave material chromatographically indistinguishable from arabitol (solvent B); no other polyol was detected. Similarly, 4/E gave material identical with threitol (solvent B); again, no other polyol was detected. Unfortunately, in neither case was sufficient product obtained for the preparation of derivatives or determination of optical rotation.

It has already been suggested that the most likely structures for 4/B/1, 4/B/2, and 4/B/3 are 1,2,3,5,6-pentaphosphate (XV), 1,2,3,4,6-pentaphosphate (XVI), and 1,2,3,4,5-pentaphosphate (XVII) (Cosgrove 1969*a*). If one again makes the assumption, by analogy with the behaviour of phytases towards *myo*-inositol hexaphosphate, that axially oriented phosphate groups are resistant to attack, then component 4/C must be the 1,2,3,6-tetraphosphate (XVIII), provided that it is a single substance and not an unresolvable mixture. It then follows that component 4/D is 1,2,6-triphosphate (XIX); the alternative, 1,2,3-triphosphate (XX), which could also give arabitol on periodate degradation, is unlikely as its formation would

involve hydrolysis at an axial position. By similar reasoning, component 4/E can be assigned the 1,6-diphosphate structure (XXI).

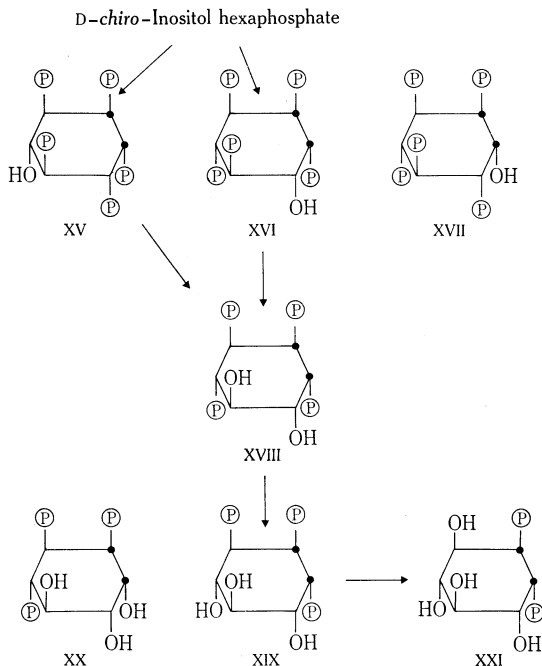

IV. CONCLUSIONS

It is now possible in many cases to correlate observed chromatographic behaviour of inositol polyphosphates with some structural features of these compounds.

TABLE 5
ORDERS OF AFFINITY OF ISOMERIC POLYPHOSPHATES FOR ANION ION-EXCHANGE RESINS

	Isomeric Polyphosphate				Reference			
	Inositol hexaphosphates							
Order of affinity	<i>scyllo</i>	>	<i>myo</i>	>	<i>chiro</i>	>	<i>neo</i>	Cosgrove (1966, 1969b)
No. of axial groups	0		1		2		2	
	<i>myo</i> -Inositol pentaphosphates							
Order of affinity	1,3,4,5,6-	>	1,2,4,5,6-	>	1,2,3,4,5-	>	1,2,4,5,6-	Cosgrove (1969a)
Position of free -OH group relative to axial position	A		A+1		A+2		A+3	
Electrophoretic mobility*	1.21		1.19		1.12		1.08	Johnson and Tate (1969b)
	D- <i>chiro</i> -Inositol pentaphosphates							
Order of affinity	1,2,3,4,5-	>	1,2,3,4,6-	>	1,2,3,5,6-			Cosgrove (1969a)
Position of free -OH group relative to axial position	A		A+1		A+2			
	<i>myo</i> -Inositol tetraphosphates							
Order of affinity			1,2,5,6-	>	1,2,3,6-			Cosgrove (1969a)
Position of free -OH groups relative to axial position			A+1		A+2		A+3	

* Relative to inorganic pyrophosphate.

From examination of Table 5 it is clear that in the examples shown the degree of affinity of isomeric polyphosphates for an anion-exchange resin is related to the position of unsubstituted groups relative to axial groups in the inositol nucleus.

For tetraphosphates of *scyllo*-inositol the order of affinity is 1,2,3,4- > 1,2,3,5- > 1,2,4,5- and here it would seem that the greater the degree of separation of the unsubstituted hydroxyl groups the less the affinity for the resin. A similar effect was noticed previously during experiments with *D*-*myo*-inositol 1,2,3,6-tetraphosphate. When it was acid-isomerized the latter gave a mixture of three tetraphosphates; the new compounds, whose unsubstituted hydroxyl groups were no longer vicinal, were eluted from the resin column more easily than the starting material (Cosgrove 1969*a*).

It appears that at least two phytases exist in biological systems; one of these, occurring mainly in plants, removes the 6-phosphate from *myo*-inositol hexaphosphate; the other, apparently restricted to microorganisms, removes the 1-phosphate. After the initial attack on the substrate molecule both enzymes continue the dephosphorylation by attacking a phosphate group adjacent to the free hydroxyl, provided that it is not an axial group. This leads to the production of two tetraphosphates in the case of bran phytase, *D*-*myo*-inositol 1,2,3,6-tetraphosphate (XXIII) and *D*-*myo*-inositol 1,2,5,6-tetraphosphate (II), whereas in the case of bacterial phytase (SB2) only one, the latter, is produced. If *L*-*myo*-inositol 1,2,3,4,5-pentaphosphate ("bran pentaphosphate") (XXII) is provided as a substrate for SB2 phytase both tetraphosphates are formed as in a bran phytase hydrolysate.

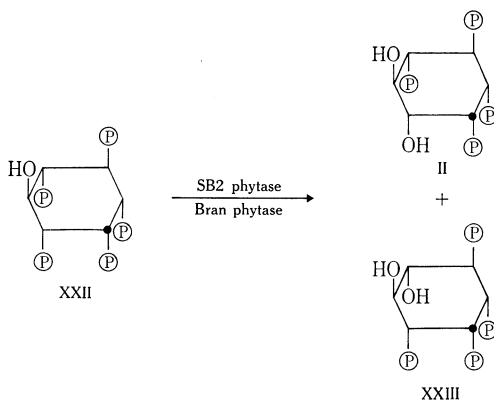

• Positions occupied by axial groups

The products isolated from SB2 phytase hydrolysates of *D*-*chiro*-inositol hexaphosphate and *scyllo*-inositol hexaphosphate in general tend to confirm the above hypothesis, i.e. after initial attack, groups adjacent to the free hydroxyl are the next to be removed. In the case of *scyllo*-inositol hexaphosphate the initial attack is very slow but the resulting pentaphosphate is more easily dephosphorylated; the same is true of hydrolysis by bran phytase (Cosgrove 1966). The initial reaction rate of hexaphosphate hydrolysis for both SB2 phytase (Irving and Cosgrove, unpublished observations) and bran phytase (Cosgrove 1966) follows the order of *myo* \simeq *neo* > *D*-*chiro* > *scyllo*. Evidently initial attack on the hexaphosphate molecule is facilitated in some way by the presence of an axial group. *D*-*chiro*-Inositol

hexaphosphate, which has two axial groups, is attacked at positions A+1 and A+2 to give a mixture of two pentaphosphates, present in roughly equal proportions, but bran phythase attacks only at position A+2 (Cosgrove 1969a).

V. ACKNOWLEDGMENTS

I wish to thank Professor S. J. Angyal, University of New South Wales, for optical rotation measurements, and Dr. R. Bramley, Australian National University, for the determination and interpretation of n.m.r. spectra. My thanks are due also to Mr. G. C. J. Irving, Division of Plant Industry, CSIRO, for assistance with some of the experimental work and for helpful discussion.

VI. REFERENCES

- ANGYAL, S. J., and RUSSELL, A. F. (1968).—*Aust. J. Chem.* **21**, 391.
 BARTLETT, G. R. (1959).—*J. biol. Chem.* **234**, 459.
 COSGROVE, D. J. (1963a).—*Biochem. J.* **89**, 172.
 COSGROVE, D. J. (1963b).—*Aust. J. Soil Res.* **1**, 203.
 COSGROVE, D. J. (1966).—*J. Sci. Fd Agric.* **17**, 550.
 COSGROVE, D. J. (1969a).—*Ann. N.Y. Acad. Sci.* **165**, 677.
 COSGROVE, D. J. (1969b).—*Soil Biol. Biochem.* **1**, 325.
 COSGROVE, D. J., IRVING, G. C. J., and BROMFIELD, S. M. (1970).—*Aust. J. biol. Sci.* **23**, 339.
 COSGROVE, D. J., and TATE, M. E. (1963).—*Nature, Lond.* **200**, 568.
 DESJOBERT, A., and PETEK, F. (1956).—*Bull. Soc. Chim. biol.* **38**, 871.
 EISENBERG, F., and BOLDEN, A. H. (1965).—*Biochem. biophys. Res. Commun.* **21**, 100.
 FRENCH, C. S., and MILNER, H. W. (1955).—“Methods in Enzymology.” (Eds. S. P. Colowick and N. P. Kaplan.) Vol. 1. p. 64. (Academic Press, Inc.: New York.)
 GRADO, C., and BALLOU, C. E. (1961).—*J. biol. Chem.* **236**, 54.
 GREAVES, M. P., ANDERSON, G., and WEBLEY, D. M. (1967).—*Biochim. biophys. Acta* **132**, 412.
 HARRAP, F. E. G. (1960).—*Analyst, Lond.* **85**, 452.
 JOHNSON, L. F., and TATE, M. E. (1969a).—*Can. J. Chem.* **47**, 63.
 JOHNSON, L. F., and TATE, M. E. (1969b).—*Ann. N.Y. Acad. Sci.* **165**, 526.
 KERR, S. E., and KFOURY, G. A. (1962).—*Archs Biochem. Biophys.* **96**, 347.
 LAUNER, H. F. (1962).—“Methods in Carbohydrate Chemistry.” (Eds. R. L. Whistler and M. L. Wolfrom.) Vol. 1. p. 377. (Academic Press, Inc.: New York.)
 LAUNER, H. F. (1963).—“Methods in Carbohydrate Chemistry.” (Eds. R. L. Whistler and M. L. Wolfrom.) Vol. 3. p. 29. (Academic Press, Inc.: New York.)
 PIZER, F. L., and BALLOU, C. E. (1959).—*J. Am. chem. Soc.* **81**, 915.
 SEIFFERT, U. B., and AGRANOFF, B. W. (1965).—*Biochim. biophys. Acta* **98**, 574.
 SMITH, I. (1960).—“Chromatographic and Electrophoretic Techniques.” Vol. 1. p. 252. (Heinemann: London.)
 TATE, M. E. (1968).—*Analyt. Biochem.* **23**, 141.
 TOMLINSON, R. V., and BALLOU, C. E. (1961).—*J. biol. Chem.* **236**, 1902.
 TOMLINSON, R. V., and BALLOU, C. E. (1962).—*Biochemistry* **1**, 166.